

D 04

Pressure reducing valve

Product specification sheet

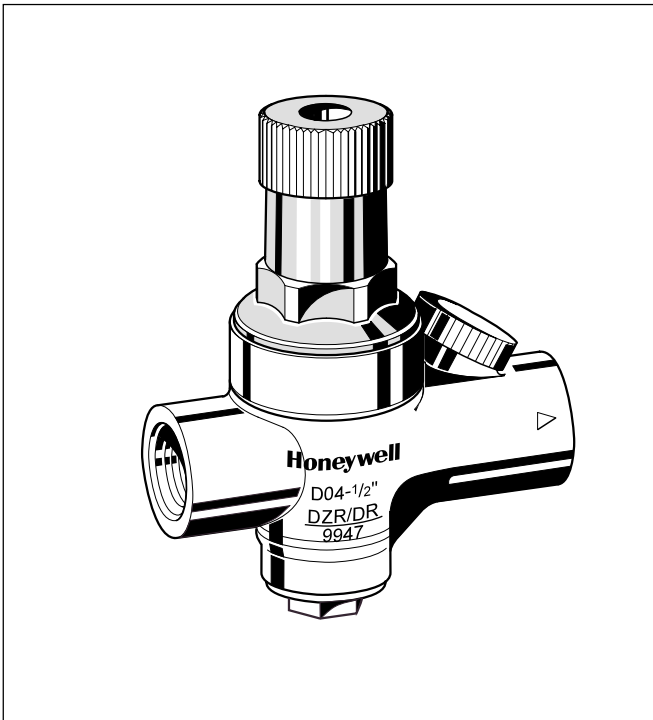

Construction

The pressure reducing valve comprises:

- Housing with G 1/4" pressure gauge connection
- Spring bonnet with adjustment opening
- Green adjustment knob
- Adjustment spring
- Pressure gauge not included (see accessories)

Materials

- Brass housing, dezincification resistant
- High-quality synthetic material spring bonnet
- Fibre-reinforced NBR diaphragm
- NBR seals
- Spring steel adjustment spring

Application

D 04 pressure reducing valves protect household water installations against excessive pressure from the supply. They can also be used for industrial or commercial applications within the range of their specification. By installing a pressure reducing valve, pressurisation damage is avoided and water consumption is reduced. The set pressure is also maintained constant, even when there is wide inlet pressure fluctuation.

Reduction of the operating pressure and maintaining it at a constant level minimizes flow noise in the installation.

Special Features

- Good value
- Simple construction
- Outlet pressure adjustable with green adjustment knob
- The adjustment spring is not in contact with the potable water
- Inlet pressure balancing – fluctuating inlet pressure does not influence outlet pressure
- Light weight

Range of Application

Medium	Water
Inlet pressure	max. 16 bar
Outlet pressure	1,5 – 6 bar adjustable

Technical Data

Operating temperature	max. 70 °C
Minimum pressure drop	1 bar
Connection sizes	1/2" and 3/4"

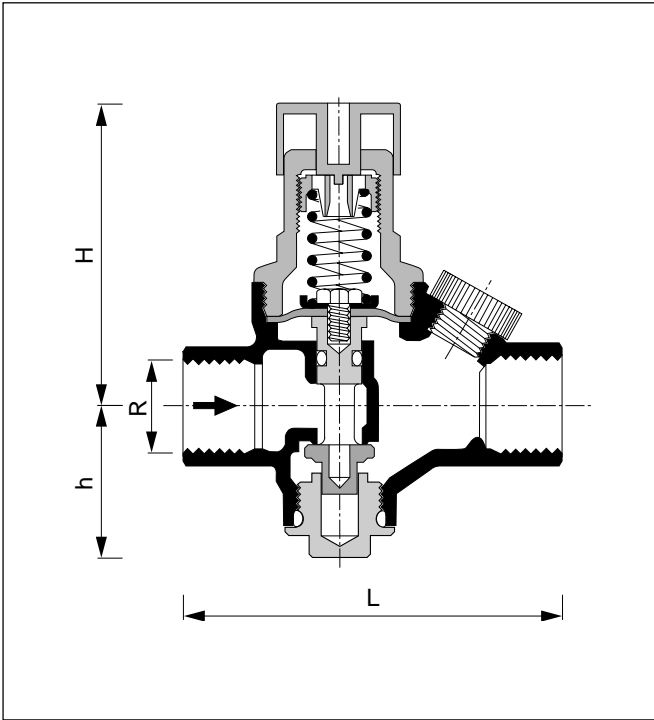

Method of Operation

Spring loaded pressure reducing valves operate by means of a force equalising system. The force of a diaphragm operates against the force of an adjustment spring. If the outlet pressure and therefore diaphragm force fall because water is drawn, the then greater force of the spring causes the valve to open. The outlet pressure then increases until the forces between the diaphragm and the spring are equal again.

The inlet pressure has no influence in either opening or closing of the valve. Because of this, inlet pressure fluctuation does not influence the outlet pressure, thus providing inlet pressure balancing.

Versions

D 04 - . . . A = Standard pattern



Connection size	R	1/2"	3/4"
Nominal size	DN	15	20
Weight	approx. (g)	327	383
Dimensions	(mm)		
	L	83	90
	H	67,5	67,5
	h	33,5	33,5
kvs-value		1,76	1,76

Accessories

M 39 K Pressure gauge

Housing diameter 63 mm, connection thread G 1/4"
 Ranges 0 - 4 bar, 0 - 10 bar,
 Please indicate upper value of pressure range when ordering

